

Single Point Load Cell

1250 Series

50-1000 Kg



FEATURES

- Anodised Aluminium
- Sealed to IP65.
- Load Cell Accuracy 0.03% RO.
- Simple to install.
- High capacity bench scales.
- 600 x 600mm maximum platform size.

APPLICATIONS

- Bench scales.
- Counting scales.
- Platform scales.
- Postal scales.





Procter & Chester Measurements

PARAMETER		UNITS
Rated Capacities	50,75,100,150,200,250,500,500 1000	Kg
Rated Output	2.0 ±10%	MV/V
Total Error	0.03	±% of Rated Output
Zero Return after 30 minutes	0.05	±% of Applied Load
Zero Balance	10	±% of Rated Output
Temperature Range: Operating	-30 to +70	°C
Temperature Range: Compensated	-10 to +40	
Temperature Effect: On Output	0.003	±% of Applied Load/°C
Temperature Effect: On zero	0.01	±% of Rated Load/°C
Safe Overload	150	% of Rated Capacity
Ultimate Overload	300	% of Rated Capacity
Excitation: Recommended	10	Volts AC or DC
Excitation: Maximum	15	
Input Impedance	415 nominal	ohm
Output Impedance	350 nominal	ohm
Insulation Impedance	>1000	megaohm
Deflection at Rated Capacity	<0.4	mm
Weight (approximate) :	NA	kg
Construction	Anodised Aluminium	
Environmental Protection	IP65	
Cable	3m 6 core screened	
Connections – Produces a positive signal in compression.	Excitation + Green Sense + Blue Excitation – Black Sense – Brown Signal + Red Signal – White	The Screen is not connected to the load cell body.
Document Revision Date	0505	

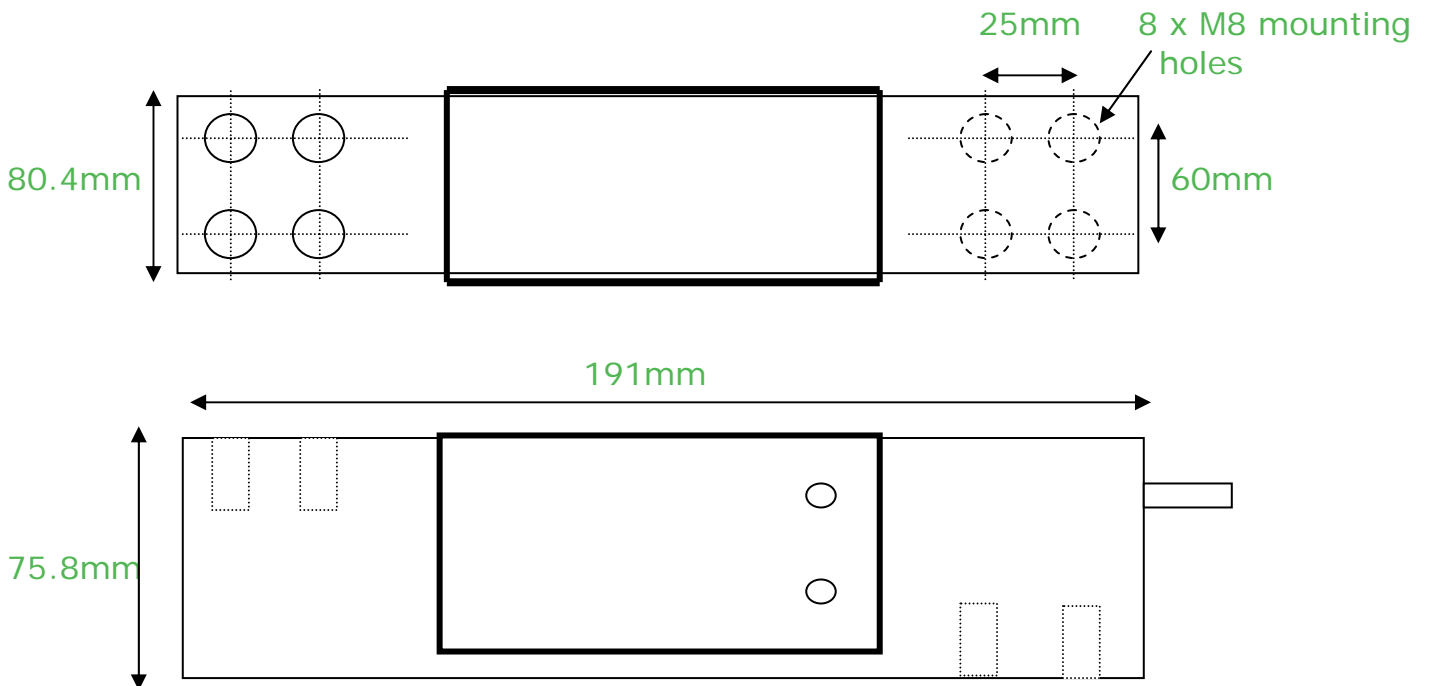

General drawing.

PCM produce custom design load cells, therefore we are able to modify the dimension and materials and build to order. PCM's policy is one of continuous improvement. We therefore reserve the right to incorporate technical modifications without prior notification. PCM are an approved ISO9001 manufacturer, Certificate No: 5527.