

## Compression Load Cell

### 220 Series

5Te- 30Te



### FEATURES

- Robust stainless steel construction
- Rugged load cell design.
- Sealed to IP68.
- Simple to install.

### APPLICATIONS

- Heavy duty weighing.
- Hopper Weighing
- Industrial Platforms.
- Test Rigs.
- Weigh bridges

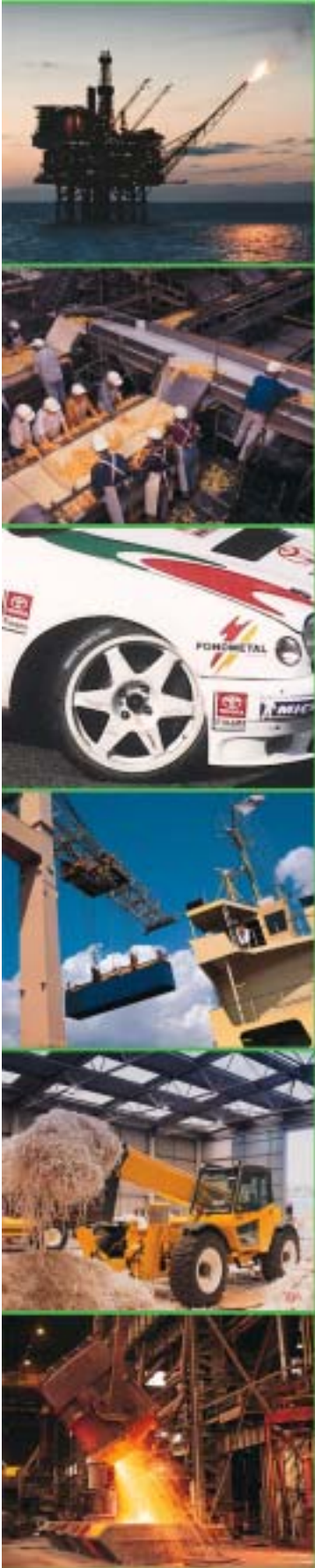



Procter & Chester Measurements

PARAMETER		UNITS
Rated Capacities	5, 10, 20, 30	Te
Rated Output	$2 \pm 0.1\%$	MV/V
Total Error	0.05	$\pm\%$ of Rated Output
Zero Return after 30 minutes	0.05	$\pm\%$ of Applied Load
Zero Balance	3	$\pm\%$ of Rated Output
Temperature Range: Operating	-30 to +70	°C
Temperature Range: Compensated	-10 to +40	
Temperature Effect: On Output	0.004	$\pm\%$ of Applied Load/°C
Temperature Effect: On zero	0.0028	$\pm\%$ of Rated Load/°C
Safe Overload	150	% of Rated Capacity
Ultimate Overload	300	% of Rated Capacity
Excitation: Recommended	10	Volts AC or DC
Excitation: Maximum	15	
Input Impedance	1065 nominal	ohm
Output Impedance	1000 nominal	ohm
Insulation Impedance	>2000	megaohm
Deflection at Rated Capacity	<0.5	mm
Weight (approximate) :	NA	kg
Construction	Stainless Steel	
Environmental Protection	IP68	
Cable	5T: 5m, 10&20T: 10m, 30Te 20m	6 wire PU Double Screened
Connections – Produces a positive signal in compression.	Excitation + Blue Sense + Green Excitation – Black Sense – Grey Signal + White Signal – Red	The Screen is not connected to the load cell body.
Document Revision Date	0904	

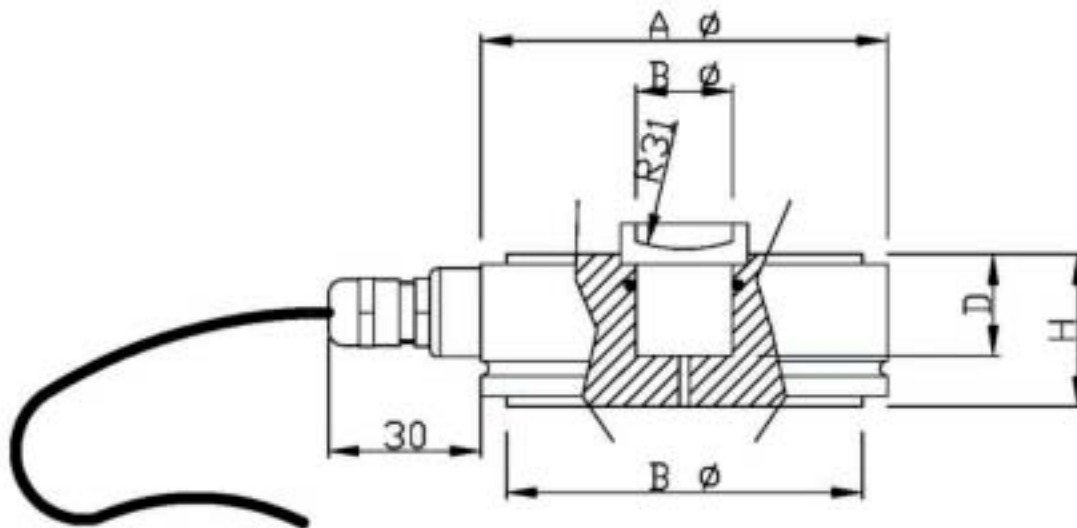

CAP.	A	B	C	D	H
5 Te	80	19	70	20	30
10Te	92	28	80	14.6	33
20Te	110	29	101.5	26.3	50
30Te	110	29	101.5	26.3	50

Dimensions in mm.

PCM produce custom design load cells, therefore we are able to modify the dimension and materials and build to order. PCM's policy is one of continuous improvement. We therefore reserve the right to incorporate technical modifications without prior notification. PCM are an approved ISO9001 manufacturer, Certificate No: 5527.