

# London Electronics Limited

Warren Court, Chicksands, Shefford, SG17 5QB, England

Tel +44 (0)1462 850967 Fax +44 (0)1462 850968



e mail: [easy4u@london-electronics.com](mailto:easy4u@london-electronics.com)  
web: <http://www.london-electronics.com>



## *Model INTUITIVE-S-TOT*

**Serial Data totaliser**



Software version LEL5.0



Document Ref:pm65\manuals\INTUITIVE\_S\_Tot Dated:31 July 2003

Rev. 7

# Notes

# Alphabetic Index

Warnings (read first please!)	2
Address Setting	8
Alarm Configuration and Adjustment	17
Analogue Output configuration and adjustment	18
ASCII characters	5
Baud Rate setting	7
Brightness Setting	16
Characters	5
Connections	6
Data Edit 'DISPLAY' setting	12
Data Edit 'LOSE' setting	11
Data Inversion facility	21
Decimal point position selection	14
Declaration of Conformity	25
Editing - Display data	12
Editing - Lose data	11
Failsafe alarm setting	17
Flash command	5
General Description	3
Getting Started	4
Hysteresis adjustment	17
Idle Timeout Setting	10
Introduction	1
Input connection examples	6
Parity Setting	9
Peak / Valley detection and memory	15
Reset command	16
Revisions record	24
Serial Communications Output	19
Software Version	1, 4 & 21
Specifications	20
String Terminator setting	13
Switches on rear panel	6
Tare Command	15
Termination character	13
Totaliser option	23
Troubleshooting	22
Warnings	2

# Introduction

Please contact us if you need help, if you have a complaint, or if you have suggestions to help us improve our products or services for you.

If you contact us about a product you already have, please tell us the full model number and serial number, so that we can give you accurate and fast help.

This product has a 2 year warranty. We will put right or replace any meter which is faulty because of bad workmanship or materials. This warranty does not cover damage caused by misuse or accident.

## ***IMPORTANT***

If this equipment is important to your process, you may want to buy a spare to cover possible failure or accidental damage in the future.

This is because at some times, for example during our factory shutdown periods, you may have to wait several weeks for an equivalent replacement. Or, we may have no stock at the time you urgently need it.

You may also need to pay extra carriage charges if you want a fast, guaranteed courier service. Warranty repairs or replacements are normally returned with a standard courier service.

We do not offer any compensation for losses caused by failure of this instrument.

If you do not agree with these conditions, please return this item now, in unused, clean condition, in its original packaging and we will refund the purchase price, excluding any carriage paid.

We thought you'd prefer to know about possible delays and extra charges now, rather than during a panic.

We always try to improve our products and services, so these may change over time. You should keep this manual safely, because future manuals, for new designs, may not describe this product accurately.

We believe these instructions are accurate, and that we have competently designed and manufactured the product, but please let us know if you find any errors.

# Warnings



**Please carefully read all warnings and ONLY install the meter when you are sure that you've covered all aspects.**

- \* Connect the meter according to current IEE regulations and separate all wiring according to IEC1010.
- \* Power supplies to this equipment must have anti-surge (T) fuses at 125mA for 230V supply, 250mA for 110V supply or 1A for DC supplies in the range 11-30VDC.
- \* Check that the model number and supply voltage suit your application before you install the meter.
- \* Don't touch any circuitry after you have connected the meter, because there may be lethal voltages on the circuit board.
- \* We designed this meter for Installation class II service only. This means it has exposed electrical and power terminals, so you must install it in an enclosure to protect users from electric shock.
- \* We designed this meter for Pollution-Degree 2 environments only. This means you must install it in a clean, dry environment, unless it has extra protection from a splashproof cover, such as our SPC4
- \* Only adjust on-board switches or connections with the power turned off
- \* Make sure all screw terminals are tight before you switch the meter on.
- \* Only clean the meter with a soft damp cloth. Only lightly dampen with water. Do not use any other solvents.

***Safety First .....Don't assume anything..... Always double check. If in doubt, ask someone who is QUALIFIED to assist you in the subject.***

# General Description

We designed the INTUITIVE-S to decode and display ASCII serial data from RS232, RS422, RS485 or 20mA TTY data ports. You can select your preferred data type by way of rear switch settings.

The main purpose of the INTUITIVE-S is to display numeric data coming from measurement systems, and from this data it can give alarm outputs, scaled analogue output and serial data retransmission.

It can also accept a limited range of alphabetic characters, but won't provide alarm or analogue outputs unless the data is purely numeric. The display can be set with up to 254 different addresses for use in multi-drop networks.

It can also extract a section of numeric data from a complex datastring, using string editing features.

The front panel has a 6 digit, 7 segment window for displaying the decoded numeric data. It allows decimal point and minus sign characters to be included and has 4 alarm annunciators to show the status of each alarm relay.

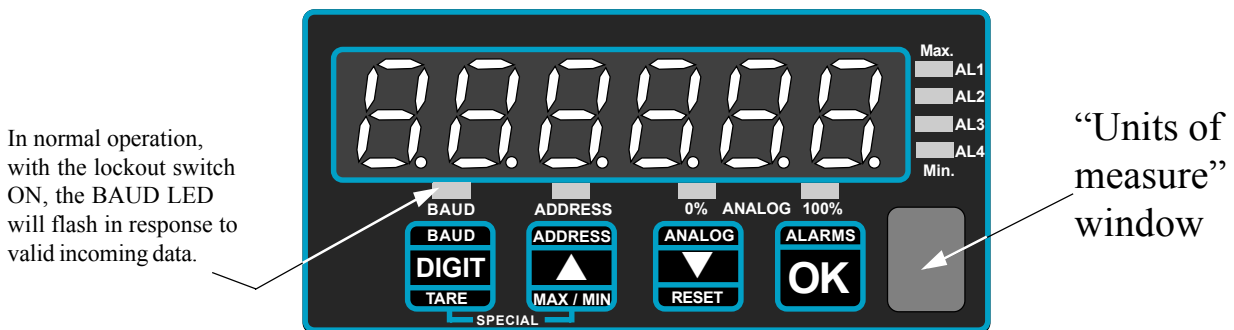

All programming adjustments are made via the front panel pushbuttons, which use LED annunciators to show which setting is being altered at any time. A clear protective window is provided, behind which you can fit one of our 'Units-of-Measure' labels, to identify the reading as Kg, or Deg. C, or Bar, etc.

A lockout switch on the rear of the meter safeguards your configuration settings in non-volatile memory, which has a 10 year guaranteed retention period. If the lockout switch is not activated, the display has no parity testing or address selection. Characters will be displayed in real time as they arrive, so long as they match the baud rate which was set via the front panel.

The display can be made to flash, and has 6 levels of selectable brightness.

# Getting Started

First, please check that the display will suit all the requirements of your application. Page 4 has some important warnings - please check that all warnings are covered.

Next, set the switches on the back of the display to suit the data type you'll be using. See page 6.

Check that your panel cutout is correct, 92mm wide, 45mm high. You must fit the meter in a protective enclosure for installation class II service. Remove the 2 screws holding the U clamp at the rear of the case. Slide the meter into the cutout and re-fit the U clamp and screws. Tighten the screws just enough to hold the meter firmly in place.

Connect the signal and power cables, to the appropriate screw terminal connectors. See page 6 to check that you are using the correct terminals.

Apply power, and confirm that the meter illuminates all segments for a few seconds and then shows the software version "SEr. 1.X" briefly (The X numeral depends on version).

The lockout switch should be OFF to allow you to change the meter's settings. Set baud rate, address, parity etc. to suit your system. Now, if you send an ASCII character of the correct baud rate, the meter should respond. With the lockout OFF, the meter will respond immediately to each valid character received, useful for initial diagnostics. However, to operate properly, and to safeguard your settings you must set the lockout switch to ON.

The TERMINAL accessory in Windows is a simple and useful application for generating serial data. It can be used to check most features of the INTUITIVE-S Here's how to connect your INTUITIVE to a PC's RS232 port...

For guidance on setting up TERMINAL, see our dedicated website help pages <http://www.london-electronics.com/terminal.htm>

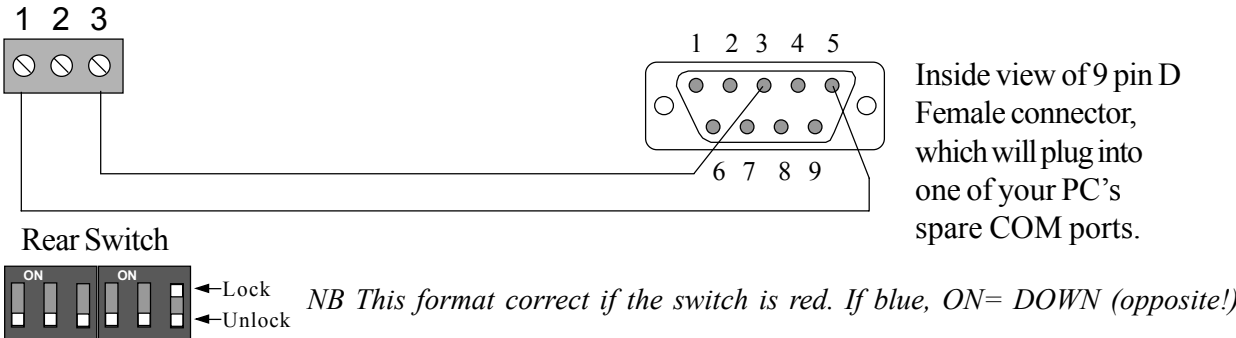





































# Recognised ASCII Characters

This display is intended mainly to show numeric ASCII characters...

0 to 9 , hex codes 30 to 39  
 decimal point, hex code 2E (or 2C)  
 and the minus sign, hex code 2D

You can FLASH the display on and off repeatedly, if you include CTRL F (ASCII 06) in the data string.

Some alphabetic characters can also be shown. Because 7 segment LEDs are limited in what they can display, capital and lower case alphabetic characters will appear the same, and some letters such as K, W and X are unrecognisable.

0		cC		oO	
1		dD		pP	
2		eE		qQ	
3		fF		rR	
4		gG		sS	
5		hH		tT	
6		iI		uU	
7		jJ		vV	
8		kK		wW	
9		lL		xX	
aA		mM		yY	
bB		nN		zZ	

ASCII hex code 20 to 2F (excluding 2C, 2D and 2E) inserts a space.

Two ESCAPE characters, (hex code 1B) will reset the display to its initial power-up condition.

# Connections

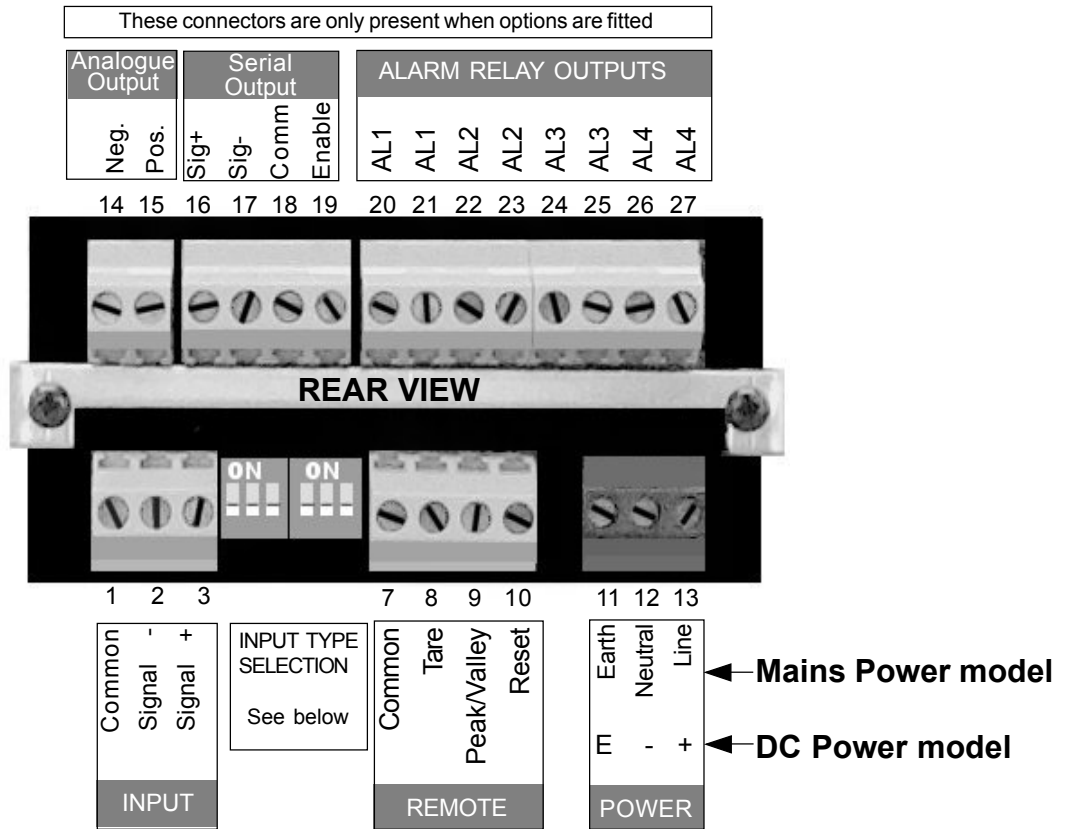

Input and contact-closure remote cabling should be screened and routed away from noise-carrying cables to prevent spurious interference.

## INPUT Connection Examples

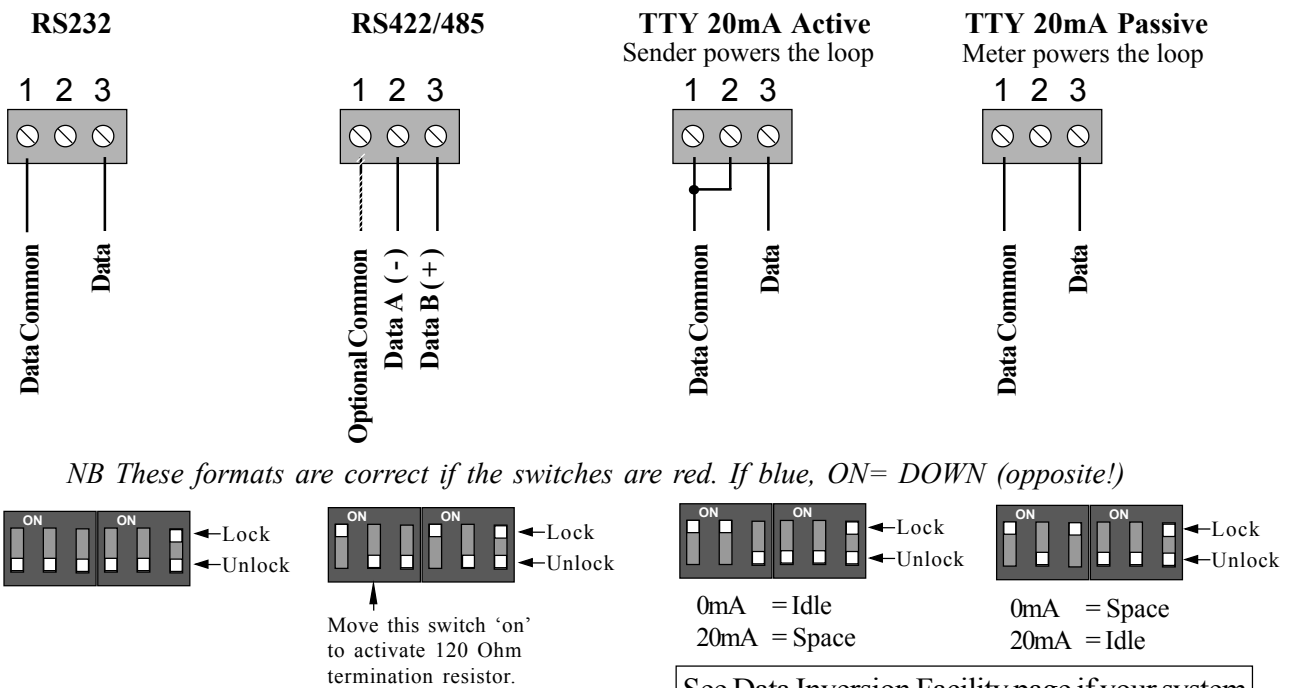

See Data Inversion Facility page if your system operates with inverted Idle/Space polarity.

### IMPORTANT!

Set the right-hand switch to its 'LOCK' (ON) position after setup, to save your settings.

## ‘BAUD RATE’ setting.

Switch the rear lockout switch to its OFF (down) position before you start to set the baud rate.

Remember to set the lockout switch ON (up) when you’ve finished, or the display won’t respond correctly.

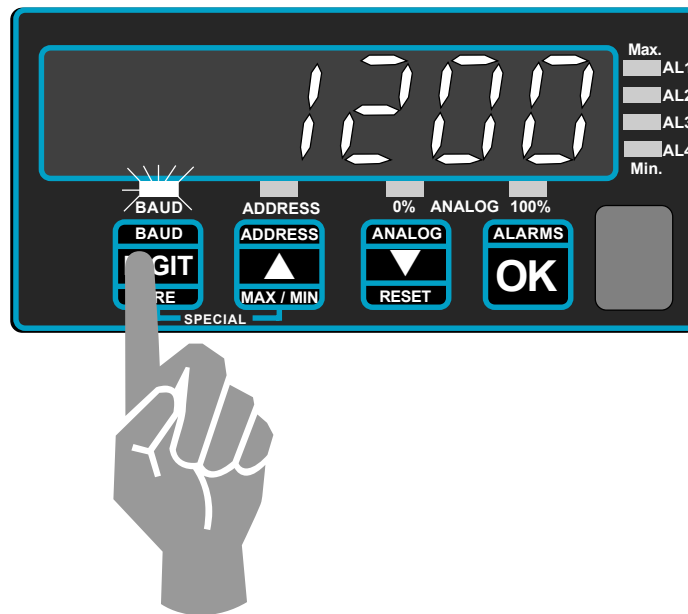

The default setting is ‘1200’

Press the button marked BAUD for a few seconds. You’ll see the meter’s existing baud rate and the ‘BAUD’ LED will flash. If you need to change the baud rate, use the UP or DOWN key. Press OK to save your choice. You can choose from 300, 600, 1200, 2400, 4800 and 9600 baud.

### Notes:

Slower baud rates allow you to use longer cabling distances. As a rough guide, with RS232, the limits are...

Baud	Max. distance
300	800 metres
600	400 metres
1200	200 metres
2400	100 metres
4800	50 metres
9600	25 metres

Balanced transmission systems such as RS422 or RS485 can allow longer transmission distances and can give better noise rejection.

## ‘ADDRESS’ Setting

Switch the rear lockout switch to its OFF (down) position before you start to set the meter’s address. Remember to set the lockout switch ON (up) when you’ve finished, or the display won’t respond correctly.

Hold in the button marked ADDRESS. The ‘ADDRESS’ LED will flash.

The meter’s address appears as *Adr.XX*, where XX is the address value.

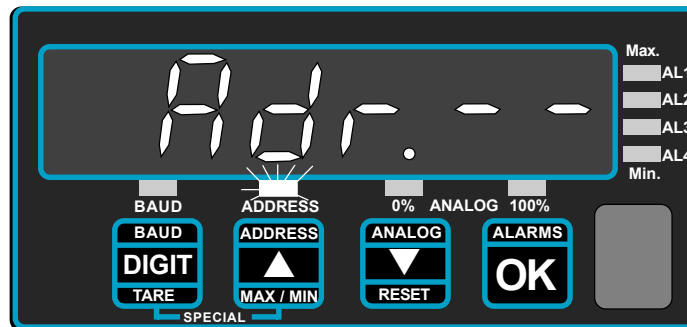

The default setting is ‘*Adr.- -*’

To change the address, use the UP/DOWN buttons. Press OK when you’ve selected the correct address.

**\* If you don’t need addressing, please choose *Adr.- -* (one less than *Adr.00*)**

If you want to address your meter, your data must be in the format:

<ETX><STX><ADDRESS><DATA><ETX> (STX = CtrlB, ETX = CtrlC)

<ETX> is ASCII code 03hex or 13hex (XOFF)

<STX> is ASCII code 02hex or 11hex (XON)

The <ADDRESS> can be either a single character, or 2 characters.

The <DATA> is ASCII format numeric data. Set String Terminator = 03 if <DATA> does not include <CR>. See page 13 for string terminator options.

***Adr.-1* to *Adr-E*** for single character addresses in the range 1-E

eg. <ETX><STX><5><123456><ETX> will display 123456 on the display with address ***Adr.-5*** A meter set to ***Adr.-0*** will respond to **all** single-digit-addressed data, regardless of address and any meter with single character addressing will respond to data with address 0 in its string

***Adr.01* to *Adr.EF*** for 2 character addresses in the range 01-EF

eg <ETX><STX><48><24680><ETX> will display 24680 on the display with address ***Adr.48*** A meter set to ***Adr.00*** will respond to **all** dual-digit-addressed data, regardless of address, and any meter with dual character addressing will respond to data with address 00 in its string.

**NB: Address Characters A to F are ASCII 3A to 3F as follows : ; < = > ?**

## ‘PARITY’ setting.

Switch the rear lockout switch to its OFF (down) position before you start to set the meter’s parity. Remember to set the lockout switch ON (up) when you’ve finished, or the display won’t respond correctly.

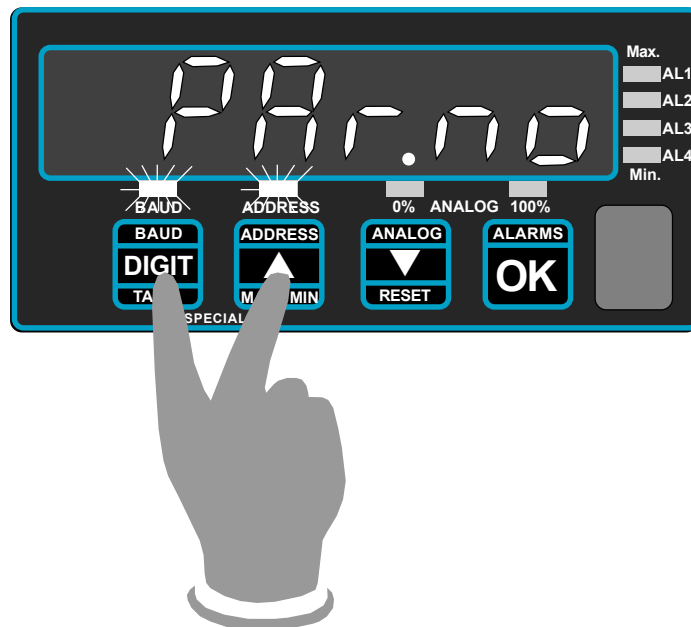

The default setting is ‘*PAR.no*’

Press both buttons marked ‘SPECIAL’ until either ‘*PAR.no*’ or ‘*PAR.Ev.*’ or ‘*PAR.od.*’ appears. You’ll also see the BAUD and ADDRESS LED’s flash together.

‘*PAR.no*’ means NO PARITY

‘*PAR.Ev.*’ means EVEN PARITY

‘*PAR.od.*’ means ODD PARITY

You can select parity choices using the UP/DOWN buttons. Press OK to save your choice.

If a parity error occurs, the display will show ‘Err P’ until valid data arrives, or until the display times-out.

Data with parity errors won’t update or affect analogue O/P or alarm status.

Note that the parity setting applies to RECEIVED data only.

The output data (if a Serial Data O/P option board is fitted) will always be in the following format : 1 start bit, 8 data bits, no parity bit, and will be at the same baud rate as the received data.

## 'IDLE' timeout setting.

The IDLE TIMEOUT is a useful feature which can be used to show when data input has been lost, or can be used to permanently display the last valid data string which was decoded - useful if data arrives infrequently, for example from an operator's manual entry keyboard. All received data will be lost if you switch the display off.

After you press 'OK' in the parity setting section, the display will show either '*IdL.no*' or '*IdL. 3*' or '*IdL.10*' or '*IdL.30*' or '*IdL.60*'

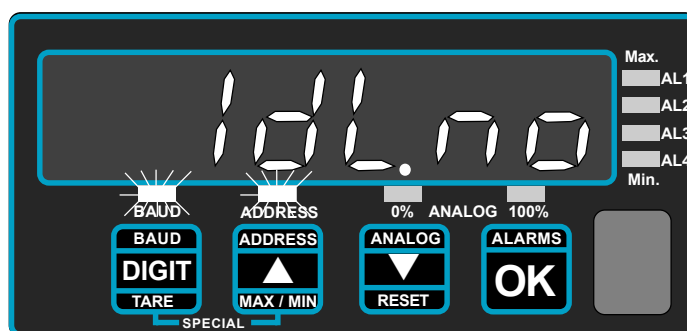

'*IdL.no*' means the display will show the last received data permanently.

'*IdL. 3*' means the display will show ----- if no data arrives for 3 seconds

'*IdL.10*' means the display will show ----- if no data arrives for 10 seconds

'*IdL.30*' means the display will show ----- if no data arrives for 30 seconds

'*IdL.60*' means the display will show ----- if no data arrives for 60 seconds

Choose one of these options using the UP/DOWN button. Press OK to save your choice.

Note: When timeout occurs, the display shows ----- , all alarms go inactive, analogue output goes to 0% and the serial output transmits one string of -----<CR> and is then idle until new valid numeric data is received and displayed. Also, nothing will happen if you activate the TARE or PEAK/VALLEY inputs.

The default setting is '*IdL.no*'

## Data edit 'LOSE' setting.

If you have a complex data string, and only want to display a certain part of it, you can use the LOSE setting to ignore(lose) a defined number of data characters. The characters we lose will be between the <CR> character and the data of interest.

For example, if your string is <STX>7768\*2505\_TY456<CR><ETX> and you only want to show the 2505 characters, you'll want to lose \_TY456 which is a group of 6 characters. Here's how we define how many characters to lose...

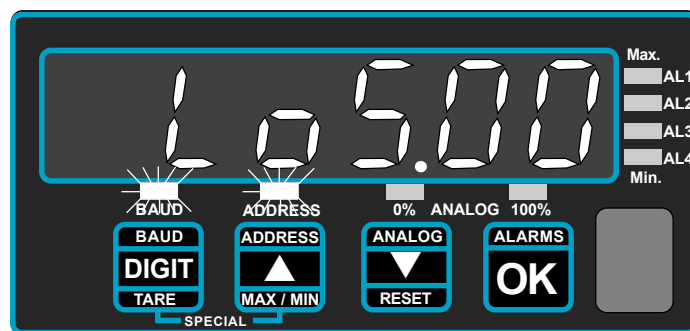

After you press the OK button in the IDLE TIMEOUT SETTING, the display will show '**LoS.XX**' where XX is the number of characters to loose.

You can use the UP and DOWN buttons to select a number of characters from 00 to 24. After choosing, press 'OK' to save your choice. In the example above, we would set '**LoS.06**'

The default setting is '**LoS.00**'

## Data edit 'DISPLAY' setting.

In the example above, we wanted to display the value 2505

If the characters to the left (7768\*) are to be ignored, we can say that we only want to display 4 characters. Here's how we set how many characters to display..

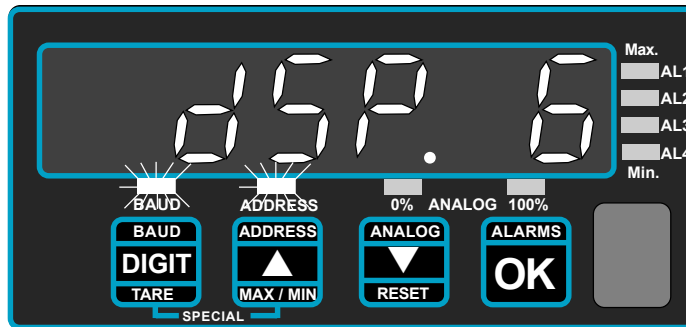

After you press the OK button after the Data edit 'LOSE' setting, the display will show '*dSP.3*' or '*dSP.4*' or '*dSP.5*' or '*dSP.6*' (*dSP* means '*display*')

You can select any one of these choices if you press the UP or DOWN button. So, we can choose to display 3, 4, 5 or 6 digits.

In our example above, we would choose '*dSP.4*'

Press 'OK' when you want to save your choice.

*An embedded decimal point isn't considered as a character, but a minus sign is considered as a character.*

The default setting is '*dSP.6*'

## String Terminator setting.

This feature is useful when the data string is complex and includes an easily identified 'datum' character which can be used as a reference for the data to be displayed. The most common string terminator is the CARRIAGE RETURN, (commonly identified as ASCII HEX 0d)

Consider a string such as:

```
:<STX>55555_ABTOL_NETT_386.9Kg_SER02345<CR><ETX>
```

where the data you wish to display is 386.9 and where the surrounding data could vary in length.

You could specify the letter K as being the datum character, if it always occurs immediately after the desired display characters and nowhere else.

The letter K is represented as 4B hex in ASCII. Here's how we would set the letter K as the string terminator...

After pressing 'OK' in the 'dSP.XX' setting, the indicator will show '*C.r. XX*' where XX is the HEX code of an ASCII character which you can choose to use as a string terminator, or carriage return.

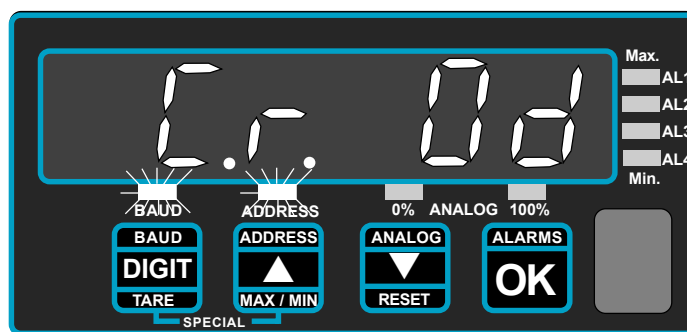

Use the UP/DOWN button to select a HEX value which suits you, (in this case you would set '*C.r. 4b*') and once chosen save by pressing the 'OK' button.

The default setting is '*C.r. 0d*' which is the normal CARRIAGE RETURN character.

## Decimal point setting.

This feature is only of interest if you are setting the meter's analogue output or Alarm relay options.

If you use either of these options, you must first know if there is a decimal point in the incoming data, and if so, where it is placed. It must be fixed, not floating, or you will get unexpected results.

If the data is sent to 2 decimal places, you must set 2 decimal places in this variable. Here's how you set the decimal point position ....

After you press the 'OK' button in the String Terminator setting, you'll see a display of **dddddd** , and there will be a decimal point lit too.

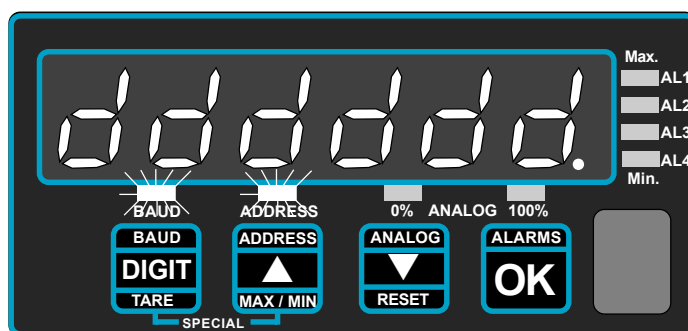

If you press the UP or DOWN button, you will see that the decimal point moves position. Keep moving the decimal point until it matches the decimal point position of the transmitted data.

When you've chosen your decimal point position, press OK to save the setting.

The default setting is **'dddddd.'**

## **Peak and Valley detection**

The meter samples the input data and compares the numeric sample to previous peaks or troughs and updates the peak or valley memory if required with the new value. You can view the stored peak and valley, either by the front panel pushbuttons or by external contact closure.

Peak is annunciated on the display by the upper alarm LED bar illuminating (identified as 'Max.' on the front panel). Valley is annunciated on the display by the lower alarm LED bar illuminating (identified as 'Min.' on the front panel). The selection of actual reading, peak and valley is sequential.

### **Front panel key viewing of Peak/Valley**

- 1) Link terminal 7 to terminal 9
- 2) Set the programme lockout switch to ON (up)
- 3) Press the UP arrow key for peak, valley, normal

### **Remote contact closure viewing of Peak/Valley**

- 1) Connect a normally-open contact closure switch between terminals 7 and 9
- 2) Set the programme lockout switch to ON (up)

**The peak or valley value will stay on the display for around 3 seconds. After this, the display will return to show input value.**

## **Tare Command**

If you want to reset the numeric display to zero at any time (for example in weighing applications), you can use the Tare command. You can do this either from the front panel, by pressing the TARE button, or by an external contact closure command. The tared value is stored in non-volatile memory.

### **Front Panel key Taring**

- 1) Link terminal 7 to terminal 8
- 2) Set the programme lockout switch to ON (up)
- 3) Press the TARE key to tare your display

### **Remote contact closure taring**

- 1) Connect a normally-open contact closure switch between terminals 7 and 8
- 2) Set the programme lockout switch to ON (up)

## **Reset Command**

The reset command clears any stored peak or valley data, and any tared offsets. You can access it either from the front panel or by external contact closure command.

### **Front Panel key reset command**

- 1) Link terminal 7 to terminal 10
- 2) Set the programme lockout switch to ON (up)
- 3) Press the Down Arrow key to reset display

### **Remote contact closure resetting**

- 1) Connect a normally-open contact closure switch between terminals 7 and 10
- 2) Set the programme lockout switch to ON (up)

## **Brightness Adjustment**

The display brightness can be set to one of 6 values to best suit the ambient lighting conditions. The lockout switch must be in the ON position to allow brightness adjustment.

Press the RESET button for >3 seconds, which will cause the display to cycle through its six brightness options. ( Caution: If you have linked terminal 7 and 10 on the rear of the meter, you will also effect a RESET command when changing the brightness level. This will clear any stored peak/valley values and any tared offset)

Release the button to save the brightness level. The meter will memorise the chosen brightness so that you won't need to readjust the brightness if power is lost.

# Alarm Configuration & Adjustment

We set our alarm outputs for failsafe operation (where contacts open on alarm or when power is lost to the meter) with jumpers set for OPEN CONTACTS and DE-ENERGISE on alarm. If you want to change this action, first remove power from meter, including any power which might be present on the alarm output circuitry.

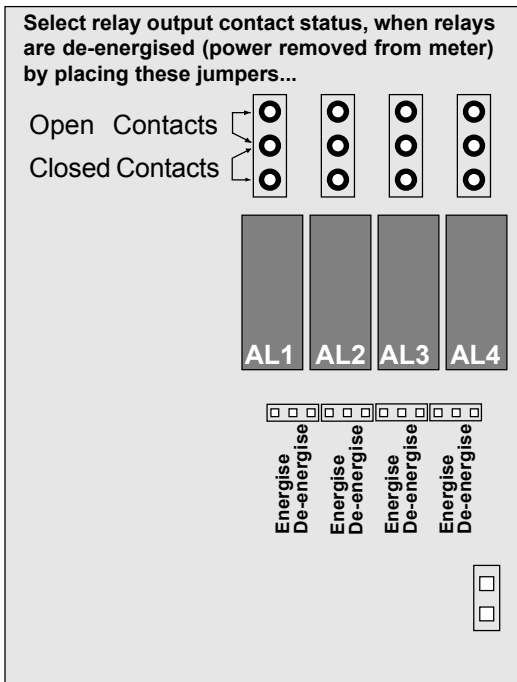

Look on the top and bottom surfaces of the case, near the rear. You will see two small screws, one on each surface.

Remove both screws. Now, clip off the front bezel and slide the meter assembly carefully out via the front of the case and separate the upper and lower cards.

To re-assemble, reverse this procedure, and be careful to ensure that the upper board is properly plugged into the lower board's connector.

## Alarm Setting

If you press the ALARMS button momentarily you can view each alarm setting (each press will illuminate in turn AL1, AL2, AL3 and AL4 annunciators)

To change alarm settings, select the alarm you wish to change as above, then press ALARM key for more than 3 seconds. You will first see the present alarm action, as HI, LO or off. You can alter this by pressing the UP or DOWN button. Press OK to save your choice. Next, you will see the actual alarm level, with one digit brighter than the others. This may be changed in value using the UP/DOWN buttons, and the digit may be selected using the DIGIT SELECT pushbutton.

The HYSTERESIS value is identified with a 'Hy' prompt, and may similarly be amended to the desired value. The hysteresis value is directly related to your measurements, so, for example, if you have a high alarm, set to 500, and set the hysteresis value to 7, the alarm will occur when the meter reading rises above 500, and will reset when the meter reading falls to 493.

# Analogue O/P Configuration & Adjustment

The analogue output board is set for either -5 to +5V, 0-10V or 4-20mA and will need no adjustment other than setting the reading values to generate 0% and 100% of output, using the front panel pushbuttons.

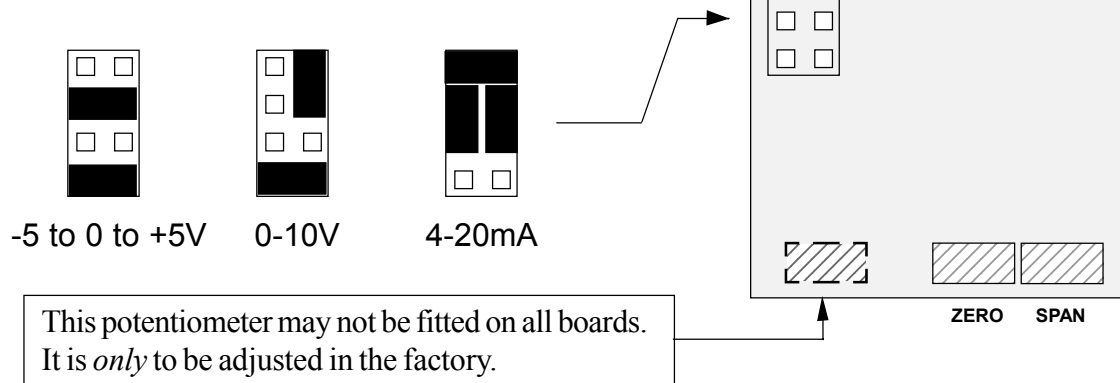

To change a range, for example from 0-10V to 4-20mA, you must reposition some jumpers as shown above, and adjust the zero and span potentiometers to get the correct output levels at 0% and 100%. Look on the top and bottom surfaces of the case, near the rear. You will see two small screws, one on each surface.

Remove both screws. Now, clip off the front bezel and slide the meter assembly carefully out via the front of the case and separate the upper and lower cards. (Unplug the board from the host to change jumper positions). Make any adjustments as required, and seal the potentiometers with varnish. To re-assemble, reverse this procedure, and be careful to ensure that the upper board is properly plugged into the lower board's connector.

## Analogue O/P Settings

Firstly, you'll need to set the rear lockout switch to 'OFF' (down)

- 1) Press the 'OUTPUT' button for 3 seconds
- 2) You should see the 0% O/P LED flash
- 3) Set the display to the reading value at which you wish to generate 0% Output by using DIGIT SELECT & UP/DOWN
- 4) When the display is correctly set, press OK
- 5) Now you should see the 100% O/P LED flashing.
- 6) Set the display to the reading value at which you wish to generate 100% Output by using DIGIT SELECT & UP/DOWN
- 7) When the display is correctly set, press OK
- 8) Set the lockout switch to 'ON' (up) when finished, to save your settings.

# Serial Communications Output

Depending on the option installed, the Intuitive will give either an RS232 or an RS422 ASCII output at a baud rate equal to the input rate you set via the front panel . You can have a continuous transmission of readings, or a single transmission on demand, provided the display has not timed out after loss of incoming data.

The serial data output will not operate if the incoming data string includes alphabetic or text characters. The numeric data must be in the range -99999 to 999999 , and can include a decimal point anywhere in the numeric value.

RS232 O/P on terminal 16 (data+) and terminal 18(common)

RS422 O/P on terminals 16 & 17(Data + and -) and 18 (common)

## String Format:

Fixed 1 Start, 8 data, no parity (regardless of the parity setting you have selected for the input signal). The string is sent as ASCII coded numerals, with embedded decimal point position if one has been set on the display, with a preceding - sign if the display is negative, with leading zero blanking, followed by a Carriage Return and a Line Feed.

So, for a displayed value of...

12345            the string will be <space><space><1><2><3><4><5><CR><LF>

-15.0            the string will be <space><space><-><1><5><.><0><CR><LF>

## Commands:

The data output port is activated via the ENABLE terminal.

For RS232, the ENABLE port, terminal 19, must be held high at a 5V level for as long as serial data output is required, or, if only one string of data is needed, the ENABLE line must be held high until such time as the transmission commences, after which it may be taken low again. The Sig- connection on terminal 17 may be used to provide the 5V level if an external source is not available

For RS422, the ENABLE port, terminal 19, operates in reverse, needing to be held low to enable transmission.(You can connect terminal 19 to terminal 18 to enable continuous transmission)

## Equipment Specifications

<b>ASCII DATA input</b>	Selectable RS422, RS485, RS232 or 20mA TTY passive and active. Data must be numeric if alarm, analogue output or serial output options are used and must be in the range -99999 to 999999.
<b>Baudrates</b>	Selectable 300, 600, 1200, 2400, 4800, or 9600
<b>Data bits</b>	7 databits with parity or 8 data bits without parity. 1 start bit, 1 or more stop bits
<b>Parity</b>	Selectable none, even or odd
<b>Addressing</b>	Can be set from 0 to E or 00 to EF or none
<b>Display update rate</b>	1 update per received datastring
<b>Timeout</b>	Display can show the last received string indefinitely, or can time-out if no data has been received for either 3, 10, 30 or 60 seconds.
<b>Termination Code</b>	Normally <CR> (Hex 13) but can be selected to be any ASCII character via front panel keys.
<b>Bezel size</b>	48mm high by 96 mm wide (1/8 DIN)
<b>Panel Cutout</b>	45mm high by 92 mm wide
<b>Case Depth</b>	125mm behind panel, including connectors
<b>Weight</b>	300 grammes typical
<b>Case Material</b>	Black polycarbonate
<b>Connectors</b>	Detachable Screw Terminal connectors
<b>Temperature</b>	Storage -10 to +70 , Operating 0 to +50 deg. C
<b>Power Supply</b>	95-265 VAC or 11-30 VDC optional
<b>Power Consumption</b>	8 Watts maximum
<b>Optional Outputs</b>	
<b>ANALOGUE O/P</b>	0-10VDC                      4-20mA                      +/-5VDC
<b>Drive capacity</b>	>1K Ohms                      <500 Ohms                      >1 K Ohms
<b>Isolation</b>	250 VAC Optically isolated
<b>Linearity</b>	+/-0.02% of range, accuracy 0.1% of range
<b>Resolution</b>	12 bits (Only responds to numeric ASCII input data)
<b>ALARM O/P</b>	2 or 4 alarms SPST rated 5A, 250 VAC, resistive load
<b>ASCII O/P</b>	RS232 or RS422 transmission of display reading.
<b>Baudrate</b>	As received, but always = 1 start, 8 data, no parity bits
<b>Isolation</b>	250 VAC optically isolated

# Data Inversion Facility

We have found that some systems use inverted data polarity, particularly in 20mA TTY applications.

If this applies to your system, you can alter an internal link pair as shown below.

Remove the board from its case and find S101 as shown below...

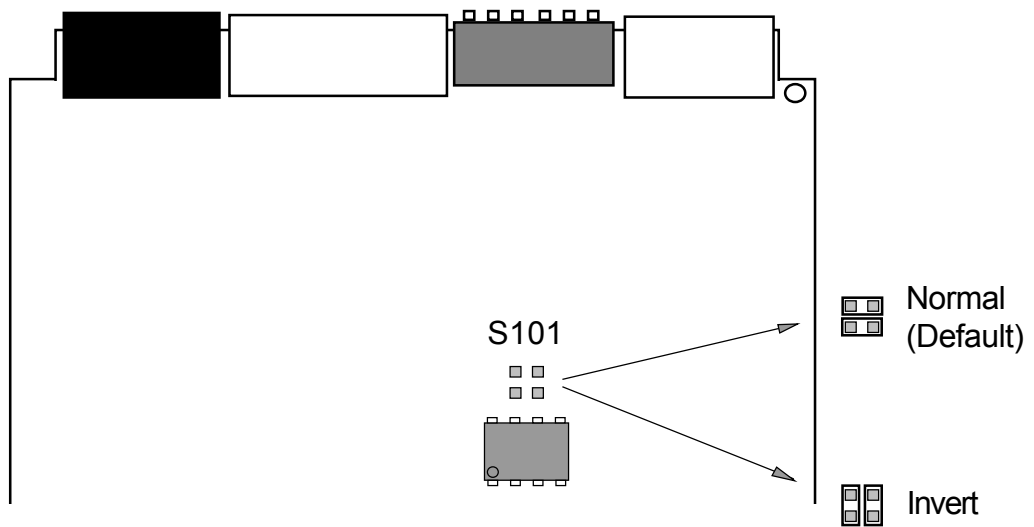

Refit the board into the case, replace the small retaining screw and re-install.

# Troubleshooting

<b>Problem</b>	<b>Possible cause and cure</b>
<p>Display updates with new data, but the value seems wrong. For example, you know you are sending 100 but the display only reads 83.</p>	<p>1. The meter may have been ‘TARED’ at some time and the tare offset value has been stored in memory and is being subtracted from new data.</p> <p>Cure: Switch the meter off. Connect terminal 7 to 10 on the rear of the display. Switch meter on. Press the RESET button on the front of the meter. Switch off and remove the link between terminals 7 and 10.</p> <p>2. Check that the Data Edit ‘DISPLAY’ and Data Edit ‘LOSE’ settings suit your data string.</p>
<p>Display shows strange illegible characters</p>	<p>1. Baud rate may be incorrect. Check that the meter has been set to the same baud rate as the transmitting device.</p> <p>2. Connections transposed. If using RS422/485, try transposing the cables to terminals 2 and 3</p> <p>If using 20mA TTY, see page 21</p>

## **Totaliser Option** Needs software version LEL5.0

A special option is available, which lets you add data strings together to show a grand total of readings.

This can be useful in weighing applications, where you may want to know the grand total weight of several batches which have been processed.

# Record of Revisions/Changes

Revisions and changes occur throughout the life of our products, and happen for several reasons..

- 1) Clients ask us for more features
- 2) Clients ask for changes to existing features
- 3) Corrections to errors in the manual
- 4) Corrections to software bugs in the product
- 5) Any other change which will improve the product

March 26 2001	Product released with software version SER. 1.0
April 3 2001	Minor text corrections to manual.
May 8 2001	Rev. 2 Manual released. Added Data Inversion Facility to page 21 Amended Alphabetic Index and Connection pages
May 17 2001	Software version 1.1 released with enhanced on-board diagnostics. Software version printed on front page. Flash command now available. Added to pages 3, 5 & index. Removed need for <CR> in addressed mode, page 8 Added more address characters. Pages 3, 16, 20 Variable display brightness added. Pages 3, 16 & index. Connection of RS422/485 amended page 6 Clarified 'active' and 'passive' for 20mA TTY page 6 Added 'Troubleshooting' page to p22. & amended index. ASCII code 2C HEX also accepted as decimal point. Page 5
8 October 2001	Analogue O/P board potentiometer layout changed. Rear switches - note added to warn of change to blue 'piano-key' switches with inverted action
14 March 2003	Clarified introduction and warnings
1 July 2003	Amended data inversion details on page 21
31 July 2003	Declaration of Conformity amended

# Declaration of Conformity

Declaration Reference : INTUITIVE  
Issue Date : 9 October 1998 revised 31 July 2003  
Products Covered : INTUITIVE series  
Title : DOC-INTUITIVE

This is to confirm that the Product covered by this declaration have been designed and manufactured to meet the limits of the following EMC Standard :

EN61326-1:1997

and has been designed to meet the applicable sections of the following safety standards

EN61010-1:2001

## Conditions

The meters are permitted a worst case error of 1% of A/D range during electro-magnetic disturbance, and must recover automatically when disturbance ceases without the need for human intervention, such as resetting, power-down etc.

The meters covered by this certificate must be installed in adherence to the following conditions :-

Signal cabling shall be routed separately to power carrying cabling (includes relay output wiring)  
All signal cabling shall be screened. The screen shall only be terminated to the power earth terminal

Declared as true and correct, for and on behalf of London Electronics Ltd.

Warren Court, Beds.

J.R.Lees Director